

ATLANTE - REQUEST FORM FOR ELECTRONIC LIMIT SWITCH

Instructions

- 1 Version:** tick the box corresponding to the version required.
- 2 Coupling, flange, pinion gear:** When a standard pinion gear is required, write the code number listed in the pinion gear tables in the next pages.
When a special pinion gear is required, write the number of teeth, the module and the primitive diameter.

Version

- Standard
- with lateral flange
- with lateral flange and pinion gear

Pinion gear

Pinion gear code _____

Customized pinion gear

No. of teeth _____

Module _____

Primitive diameter _____

Moulded pinion gears

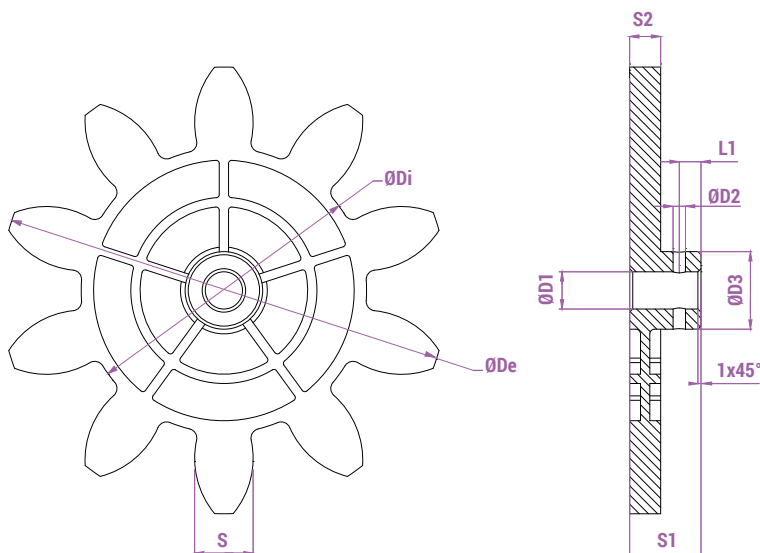

Legend	
Z	Number of teeth
M	Module
Dp	Primitive diameter
De	External diameter
Di	Internal diameter
a	Addendum
d	Dedendum
Alpha	Pressure angle

Code	Z	M	Dp	De	Di	a	d	S	Alpha	D1	D2	D3	S1	S2	L1
PRSL0855PI	8	24,00	192,00	240,00	136,00	24,00	28,00	38,1	20,00	12,00	4,00	24,00	23,00	10,00	7,00
PRSL0915PI	8	20,00	160,00	200,00	113,20	20,00	23,40	31,41	20,00	12,00	4,00	24,00	23,00	10,00	7,00
PRSL0912PI	10	12,00	120,00	144,00	92,00	12,00	14,00	18,85	20,00	12,00	4,00	25,00	23,00	10,00	7,00
PRSL0913PI	10	14,00	140,00	168,00	107,24	14,00	16,38	21,99	20,00	12,00	4,00	24,60	23,00	10,00	7,00
PRSL0914PI	10	16,00	160,00	192,00	122,67	16,00	18,67	25,13	20,00	12,00	4,00	24,00	23,00	10,00	7,00
PRSL0917PI	11	6,00	66,00	78,00	51,96	6,00	7,02	9,42	20,00	12,00	4,00	19,00	23,00	8,00	7,00
PRSL0916PI	12	5,00	60,00	70,00	48,30	5,00	5,83	7,85	20,00	12,00	4,00	20,00	23,00	8,00	7,00
PRSL0918PI	12	8,00	96,00	112,00	77,28	8,00	9,36	12,56	20,00	12,00	4,00	21,50	23,50	10,00	7,00
PRSL0911PI	12	10,00	120,00	140,00	96,67	10,00	11,67	15,71	20,00	12,00	4,00	25,00	23,50	10,00	7,00
PRSL0944PI	12	12,00	144,00	168,00	116,00	12,00	14,00	18,85	20,00	12,00	4,00	24,00	23,00	10,00	7,00

Measuring unit: mm.

Waterjet cut pinion gears 2

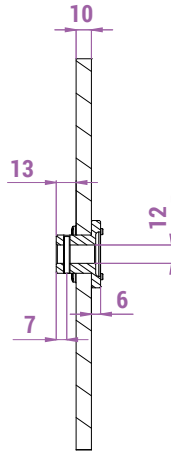
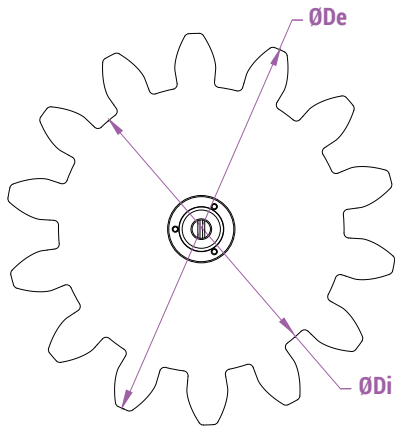

Legend

Z	Number of teeth
M	Module
Dp	Primitive diameter
De	External diameter
Di	Internal diameter
a	Addendum
d	Dedendum
Alpha	Pressure angle

Code	Z	M	Dp	De	Di	a	d	Alpha
PRSL0857PI	8	18,00	144,00	180,00	102,00	18,00	21,00	20,00
PRSL0992PI	9	10,00	90,00	110,00	66,67	10,00	11,67	20,00
PRSL0879PI	9	16,00	144,00	176,00	106,67	16,00	18,67	20,00
PRSL0854PI	9	18,00	162,00	198,00	120,00	18,00	21,00	20,00
PRSL0871PI	9	20,00	180,00	220,00	133,33	20,00	23,33	20,00
PRSL0849PI	9	24,00	216,00	264,00	160,00	24,00	28,00	20,00
PRSL0846PI	10	10,00	100,00	120,00	76,67	10,00	11,67	20,00
PRSL0993PI	10	18,00	180,00	216,00	138,00	18,00	21,00	20,00
PRSL0970PI	10	22,00	220,00	264,00	168,52	22,00	25,74	20,00
PRSL0856PI	10	24,00	240,00	288,00	184,00	24,00	28,00	20,00
PRSL0861PI	11	12,00	132,00	156,00	104,00	12,00	14,00	20,00
PRSL0998PI	11	18,00	198,00	234,00	156,00	18,00	21,00	20,00
PRSL0997PI	11	20,00	220,00	260,00	173,36	20,00	23,32	20,00
PRSL0859PI	11	24,00	264,00	312,00	204,00	24,00	30,00	20,00
PRSL0863PI	12	14,00	168,00	196,00	133,00	14,00	17,50	20,00
PRSL0897PI	12	16,00	192,00	224,00	154,67	16,00	18,67	20,00
PRSL0972PI	12	18,00	216,00	252,00	173,88	18,00	21,06	20,00
PRSL0845PI	12	20,00	240,00	280,00	193,34	20,00	23,32	20,00
PRSL0878PI	12	24,00	288,00	336,00	232,00	24,00	28,00	20,00
PRSL0860PI	13	6,00	78,00	90,00	63,00	6,00	7,50	20,00
PRSL0853PI	13	12,00	156,00	178,59	126,00	11,29	15,00	20,00
PRSL0898PI	13	16,00	208,00	240,00	170,67	16,00	18,66	20,00
PRSL0862PI	14	10,00	140,00	169,00	125,00	15,00	7,50	20,00
PRSL0896PI	14	16,00	224,00	256,00	186,67	16,00	18,67	20,00
PRSL0999PI	14	18,00	252,00	288,00	210,00	18,00	21,00	20,00
PRSL0848PI	14	20,00	280,00	320,00	233,33	20,00	23,33	20,00
PRSL0858PI	15	18,00	270,00	306,00	228,00	18,00	21,00	20,00
PRSL0847PI	16	20,00	320,00	360,00	273,33	20,00	23,33	20,00
PRSL0973PI	17	10,00	170,00	190,00	145,00	10,00	12,50	22,89
PRSL0974PI	17	14,00	238,00	266,00	203,00	14,00	17,50	22,89
PRSL0851PI	20	6,00	120,00	132,00	105,00	6,00	7,50	22,89

Measuring unit: mm.